

Copy for Official Use

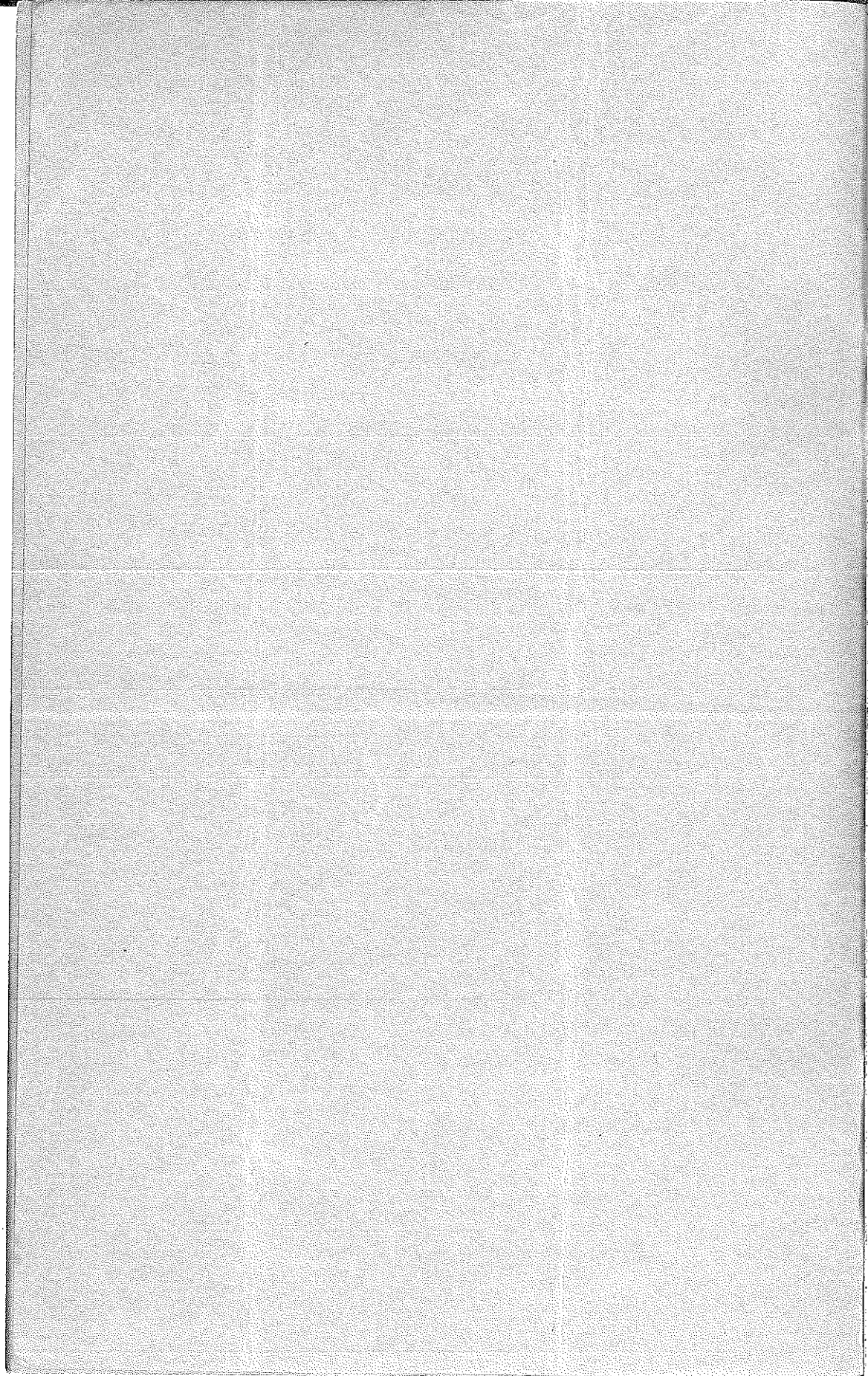
AIR MINISTRY  
METEOROLOGICAL OFFICE  
FORM 63

# Instructions for making Thermometer Screens of the Stevenson type

*(Revised in the Meteorological Office 1937)*



LONDON  
HIS MAJESTY'S STATIONERY OFFICE  
Price 6d. net



Copy for Official Use

AIR MINISTRY  
METEOROLOGICAL OFFICE  
FORM 63

# Instructions for making Thermometer Screens of the Stevenson type

*(Revised in the Meteorological Office 1937)*

*Crown Copyright Reserved*



LONDON

PRINTED AND PUBLISHED BY HIS MAJESTY'S STATIONERY OFFICE

To be purchased directly from H.M. STATIONERY OFFICE at the following addresses:  
York House, Kingsway, London, W.C.2 ; 120 George Street, Edinburgh 2 ;  
26 York Street, Manchester 1 ; 1 St. Andrew's Crescent, Cardiff ;  
80 Chichester Street, Belfast ;  
or through any bookseller

1937

*Reprinted 1939*

Price 6d. net

# Instructions for making Thermometer Screens of the Stevenson type

(Revised in the Meteorological Office, 1937)

## List of Illustrations

- Fig. 1. Standard Type Screen—front elevation.
- Fig. 2. Standard Type Screen—Section across centre line of screen showing louvres of back and door, bottom boards and thermometer support.
- Fig. 3. Standard Type Screen—Section across centre line of screen showing side louvres, thermometer support and water bottle fixture.
- Fig. 4. Standard Type Screen—Side elevation showing rear door securing plates.
- Fig. 5. Support for sheathed thermometers. (Wet and dry bulb maximum and minimum.)
- Fig. 6. Details of air vents (all types of screens).
- Fig. 7. Details of louvres, posts and strips for standard and large type screens.
- Fig. 8. Standard type screen—plan.
- Fig. 9. Wooden stand for standard and large type screens.
- Fig. 10 and 11. Sections across centre lines of standard type screen showing modifications for accommodating two recording instruments.
- Fig. 12. Plan of upper shelf for supporting self-recording instrument in standard type screen.
- Fig. 13. Plan of lower shelf for supporting self-recording instrument in standard type screen.
- Fig. 14. Large type screen—front elevation.
- Fig. 15. Small type screen—front elevation partly sectioned on centre line to show side louvres and thermometer supports.
- Fig. 16. Small type screen—end elevation.
- Fig. 17. Small type screen—details of louvres, posts and strips.
- Fig. 18. Steel stand for standard and large types of screen.
- Fig. 19. Steel stand for small type screen.
- Fig. 20. Support for thermometers with porcelain scales.

## 1.—STANDARD PATTERN

*Material.*—The screen, which is designed to take maximum, minimum, dry and wet bulb thermometers, is to be constructed throughout of the best yellow pine and all its parts should be put together with tenons, mortices and brass screws with the exception of the louvres which should be secured in their places by brass pins.

*Dimensions.*—The clear *internal* dimensions are to be: width 18 inches, depth 12 inches and height  $16\frac{1}{2}$  inches.

*Framework.*—This consists of four posts connected above and below by rails. The two front posts are to be  $1\frac{1}{2}$  inches square, 22 inches high, and the clear space between them  $19\frac{1}{2}$  inches. The two back posts are to be  $1\frac{1}{2}$  inches square, 21 inches high, and the clear space between them  $19\frac{1}{2}$  inches. The clear distance between the front and back posts must be  $12\frac{1}{2}$  inches. The lower rails are all to be  $1\frac{1}{2}$  inches square in section and their undersides must be  $1\frac{1}{2}$  inches above the bottom ends of the corner posts. The upper rails are to be  $1\frac{1}{2}$  inches wide and 1 inch deep. The clear space between the upper and lower rails must measure  $15\frac{1}{2}$  inches.

*Louvres.*—The screen has, on each side, 13 double louvres  $\frac{5}{16}$  inch thick. The outer louvres are to be  $1\frac{13}{16}$  inches wide and are to be supported at each end in slots  $\frac{5}{16}$  inch wide and  $\frac{3}{16}$  inch deep cut into the corner posts and door frames and pinned diagonally as shown in Fig. 7, the edges then being planed flush with the side of the screen. The inner louvres are  $1\frac{3}{8}$  inches wide and are supported at each end in similar slots cut into supporting strips of  $\frac{3}{4}$  inch by  $\frac{1}{2}$  inch cross section. These strips are then screwed to the corner posts and door frames. When those screwed to the corner posts are correctly placed there will be a space of  $\frac{1}{16}$  inch between the strip and the door face (see Fig. 8). When assembled, there will be an air space  $\frac{5}{16}$  inch wide between the outer and inner louvres.

*Doors.*—The doors form the front and rear of the screen and consist of rectangular frames, 1 inch by  $1\frac{1}{2}$  inch section, with 11 double louvres as shown in Fig. 7. The width of an outer louvre is  $1\frac{3}{8}$  inches, that of an inner one  $1\frac{3}{8}$  inches. Each door is to be provided with two 3-inch brass butt hinges,  $\frac{1}{8}$  inch thick, of very strong superior make with brass pins, screwed by  $\frac{3}{4}$ -inch No. 6 countersunk brass wood-screws to the lower rail thus enabling the doors to be closed flush with the corner posts. A clearance of  $\frac{1}{8}$  inch is to be allowed on each side between door frame and corner posts and at the top and bottom between door frame and rails. The front door is to be provided with a 13 S.W.G. brass hasp and staple secured by No. 2 B.A. brass round head bolts  $1\frac{3}{4}$  inches long with lock nuts and strong brass turn 3 inches long firmly secured by  $\frac{3}{4}$ -inch No. 6 countersunk brass wood-screws, and a suitable length of stamped brass chain (24 S.W.G.) hooked (hook 11 S.W.G. brass) to the right-hand post and secured to the door by a brass screw eye (11 S.W.G.). The rear door is identical with the front door but is provided with

two brass securing plates  $1\frac{1}{2}$  inches by  $\frac{1}{2}$  inch, 15 inches apart, let in flush and secured by two No. 2 B.A. brass round head bolts  $1\frac{3}{4}$  inches and  $1\frac{1}{4}$  inches long respectively, with lock nuts, in place of the hasp and staple, turn and chain, as shown in Fig. 4.

*Bottom of Screen.*—This is formed by three  $\frac{1}{2}$ -inch thick overlapping boards shown in section in Fig. 2. The centre board is 6 inches wide and has a slot  $2\frac{5}{8}$  inches by 1 inch cut out of it to take the thermometer support—see Fig. 8. It has a mahogany cylinder  $1\frac{5}{8}$  inches internal diameter by  $2\frac{5}{8}$  inches external diameter by 1 inch high screwed to it to take the water bottle. This board is let into the top of the lower rails of the frame—see Fig. 3. The other two boards, each  $4\frac{3}{4}$  inches wide, are screwed to the undersides of the end rails (Fig. 2) in such a way that each overlaps by  $1\frac{1}{2}$  inches the ends of the centre board above.

*Roof.*—The roof is a double one. The inner roof is  $\frac{1}{2}$  inch thick. It rests upon the upper rails and is cut away to clear the corner posts. It should have 10 holes, each  $1\frac{1}{16}$  inches in diameter, cut in it, as shown in Fig. 8. A tube of brass,  $1\frac{1}{8}$  inches outside diameter,  $\frac{1}{16}$  inch thick and  $\frac{7}{8}$  inch long, is forced into each hole—see Fig. 6. A wooden block  $2\frac{1}{2}$  inches by 1 inch by 1 inch is screwed to the underside of the inner roof to be in line with the slot in the centre board of the bottom of the screen—Figs. 2 and 3. The outer roof is constructed from a piece of selected timber 1 inch thick and measures  $26\frac{1}{2}$  inches by  $19\frac{1}{2}$  inches. It is supported at the ends by two strips filleted and tenoned to it as shown in Figs. 3 and 4 and is secured by brass woodscrews as shown in Fig. 4. The underside of the outer roof should be 2 inches above the inner roof in front, but only 1 inch above it at the back and it must project 2 inches all round beyond the sides of the screen (Figs. 2 and 3). A strip of wood  $\frac{1}{2}$  inch thick and  $1\frac{1}{2}$  inches wide is let into the front corner posts in the space between the inner roof and the outer roof—see Figs. 1 and 2. The space between the inner and outer roofs is blocked with wood on each side except for an opening 6 inches by  $\frac{3}{4}$  inch on the centre line as shown in Figs. 2, 3 and 4. A sheet of asbestos cement  $\frac{3}{16}$  inch thick, overlapping  $\frac{1}{4}$  inch all round, is screwed to and covers the outer roof.

*Thermometer Support for Sheathed Thermometers.*—This is of well-seasoned straight-grained polished mahogany. It consists of an upright  $2\frac{1}{2}$  inches wide,  $\frac{1}{2}$  inch thick and 18 inches high supporting two cross pieces cut as shown in Fig. 5. The upper cross piece,  $7\frac{1}{8}$  inches long, carries two clips detailed in Fig. 5A. The lower cross piece, 8 inches clear space below the upper cross piece, is  $10\frac{1}{2}$  inches long. It carries two hooks, and a block at each end is screwed and glued to it. Two spring clips (Fig. 5B) are mounted on each of these blocks. Care should be taken that the vertical slots in the two cross pieces should be shaped with semi-circular ends  $\frac{3}{16}$  inch wide and  $\frac{1}{2}$  inch deep and that when the cross pieces are in position

these slots are in line. The clips (Fig. 5A) are formed from No. 16 S.W.G. brass sheet and must be firmly screwed to the upper cross piece. It is essential for the slots in these clips,  $\frac{9}{32}$  inch wide and  $\frac{5}{8}$  inch deep, to be central with the vertical slots in the cross piece. The dimensions shown in Fig. 5A should be adhered to carefully. The hooks are formed from No. 24 S.W.G. phosphor bronze strip. The fixing screws are to be of sufficient length to allow for adjusting the pressure exerted by the hooks. The spring clips detailed in Fig. 5B are of approximately No. 20 S.W.G. brass and can be purchased as a manufactured article. The right-hand pair of clips are to be mounted  $\frac{1}{4}$  inch higher than the left-hand pair.

The thermometer support† is fixed in position in the screen by screwing the top end of the support to the 1 inch by 1 inch by  $2\frac{1}{2}$  inch wooden block screwed to the inner roof, shown in Fig. 2. The lower end is fitted and screwed into the slot provided for it in the centre board of the bottom of the screen—see Figs. 2 and 8.

*Painting.*—The following methods may be used :

(a) Synthetic lacquer. In this case apply two undercoats of white lead paint before assembly, and three finishing coats of white synthetic lacquer after assembly.

(b) Zinc paint. In this case apply one undercoat of mixed red and white lead primer before assembly and three finishing coats of zinc oxide\* paint after assembly.

(c) Instead of synthetic lacquer, any good white enamel paint may be used, two undercoats being applied before, and one or two finishing coats of enamel after assembly.

The framework, support and mahogany cylinder on the centre board should not be painted, but varnished. The metal parts should be polished and coated with good quality outdoor copal varnish.

## 2.—MODIFICATION TO STANDARD SCREEN TO TAKE RECORDING INSTRUMENTS

The standard screen allows of two autographic instruments—the thermograph and hygrograph—being inserted in it in place of the usual thermometers. Figs. 10 and 11 show the plan adopted. The two cross pieces are omitted from the upright of the thermometer support. A piece of wood  $\frac{1}{2}$  inch thick is fastened to the middle bottom board of the screen and is provided with edge pieces, Fig. 13, leaving a clear space  $5\frac{1}{2}$  inches by  $9\frac{1}{2}$  inches for the hygrograph.

\* This should be either British Standard Specification No. 277 (ready mixed paint, zinc oxide base) or British Standard Specification No. 273 (zinc oxide oil paste for paints).

† For a design of support suitable for use with thermometers having porcelain scales and maximum and minimum thermometers having wooden mounts, see Plate IX.

The thermograph stands above the hygrograph on a shelf measuring about 8 inches by  $5\frac{1}{2}$  inches within the edge pieces. This shelf is secured to the thermometer support 8 inches above the bottom board by a piece of  $2\frac{1}{2}$  inches by  $1\frac{1}{2}$  inches by  $\frac{1}{4}$  inch mild steel angle 2 inches long held in position by six No. 10  $\frac{5}{8}$ -inch brass countersunk woodscrews. It greatly facilitates the handling of both recorders if the shelf is shaped as shown in Fig. 12.

### 3.—LARGE SCREEN

This screen is designed to accommodate both thermograph and hygrograph in addition to the four thermometers. The construction is similar to the standard screen but the clear distance between the posts is 41 inches and all the lengthwise dimensions are increased accordingly—Fig. 14. On account of their length the louvres of the doors are made in two sections with supporting posts and strips in the centre. Both front and rear doors are identically constructed and each has three 3-inch brass butt hinges, of very strong superior make with brass pin, screwed to the lower rail, thus enabling the doors to be closed flush with the corner posts—see Fig. 14. The front door, which opens downwards, is provided with a brass turn hasp and staple and suitable lengths of brass chain hooked to the right- and left-hand posts and secured to the door by brass screw eyes—Fig. 14. The rear door is to be provided with brass securing plates—Fig. 4. The inner roof has 18 holes—Fig. 14—brass lined as in Fig. 6.

### 4.—SMALL STEVENSON SCREEN SUITABLE ONLY FOR SHEATHED THERMOMETERS

The advent of sheathed thermometers has made possible a smaller type of screen than the standard.

*Material.*—Woodwork best yellow pine, except for water bottle fixture (mahogany). All metal fittings (including screws) brass.

*Dimensions.*—The clear *internal* dimensions are to be: width  $16\frac{1}{2}$  inches, depth  $6\frac{1}{4}$  inches and height 12 inches

*Framework.*—This consists of four corner posts connected above and below by rails let into the corner posts and screwed to them. These posts are to be  $1\frac{3}{8}$  inches square, each post  $14\frac{1}{4}$  inches in length tapering to  $13\frac{3}{4}$  inches to suit span type of roof and 18 inches apart both back and front. The clear distance between the back and front posts must be 7 inches. The upper and lower rails are 1 inch by  $1\frac{3}{8}$  inches, the clear space between them being  $11\frac{1}{2}$  inches—see Figs. 15 and 16.

*Louvres.*—The outer louvres are constructed from 2 inches by  $\frac{5}{16}$  inch section and for the ends (9 louvres each end) are  $7\frac{3}{8}$  inches long secured in  $\frac{3}{16}$  inch deep slots cut in the corner posts and pinned.

For the door the louvres (7 in number) are  $15\frac{3}{8}$  inches long secured in  $\frac{3}{16}$  inch deep slots in the frame and pinned, and for the back (10 in number) are of the same size and are similarly secured, the slots being cut in the two 1 inch by  $1\frac{1}{2}$  inches section uprights.

The inner louvres are constructed from  $1\frac{1}{2}$  inches by  $\frac{5}{16}$  inch section and are let into grooves  $\frac{3}{16}$  inch deep in the  $\frac{3}{4}$  inch by  $\frac{3}{8}$  inch section securing strips and pinned. The completed sets are then secured by screws through the strips. The lengths are  $15\frac{3}{8}$  inches for the door and back,  $7\frac{3}{8}$  inches for the ends.

The edges of all the louvres are bevelled as shown in Fig. 17 and when assembled there must be an air gap  $\frac{1}{4}$  inch wide between the inner and outer louvres.

*Door.*—This forms the front of the screen and consists of a rectangular frame of  $1\frac{3}{8}$  inches by 1 inch section with mortised joints carrying seven double louvres. The door is provided with two 2-inch brass butt hinges of very strong superior make with brass pins, screwed by  $\frac{3}{4}$  inch No. 8 countersunk brass woodscrews to the lower rail thus enabling the door to be closed flush with the corner posts. A clearance of  $\frac{1}{8}$  inch is to be allowed on each side between the door frame and the corner posts and at top and bottom between the door frame and the rails. A strong brass turn 3 inches long is to be provided and sufficient length of 24 S.W.G. stamped brass chain to allow the door to open to a horizontal position, the chain to be hooked to the door by a 11 S.W.G. hook and secured to the right-hand post by a 11 S.W.G. screw eye. A 13 S.W.G. hasp and staple to be provided (see Figs. 15 and 16).

*Bottom of Screen.*—This is formed of three overlapping boards. The centre board, the dimensions of which are 3 inches by  $\frac{1}{2}$  inch by  $20\frac{3}{4}$  inches, is screwed to the upper sides of the side rails. Two blocking pieces 2 inches by  $1\frac{1}{4}$  inches by  $\frac{1}{2}$  inch are also to be screwed to the upper sides of these rails. This central board is slotted  $\frac{3}{4}$  inch wide by  $\frac{1}{2}$  inch deep to take two  $\frac{3}{4}$  inch by  $\frac{1}{2}$  inch strips, the two slots being 7 inches clear distance apart. The clear distance between the inside of the left-hand corner post and the left-hand slot is  $5\frac{3}{4}$  inches. A mahogany block,  $2\frac{3}{8}$  inches square by 1 inch high with  $1\frac{1}{8}$  inches diameter hole is screwed to the board so that its centre line is  $3\frac{3}{4}$  inches from the outside edge of the left-hand strip. The outer boards which are each  $4\frac{1}{8}$  inches by  $\frac{1}{2}$  inch by  $20\frac{3}{4}$  inches, are screwed to the underneath of the posts and lower rails.

*Roof.*—The roof is a double one (see Fig. 15). The inner roof is  $\frac{1}{2}$  inch thick and rests upon the upper rails, being cut away to clear the corner posts. It has three 1 inch holes, each 1 inch in diameter at the bottom and  $1\frac{1}{8}$  inches diameter in the upper part, drilled along its centre line. Three brass tubes are forced into these vent holes. These tubes are  $1\frac{1}{8}$  inches external diameter by  $\frac{1}{16}$  inch thick by  $\frac{7}{8}$  inch

long. The outer roof is of the span type  $23\frac{3}{4}$  inches long by  $\frac{3}{4}$  inch thick and is made of two boards secured at the ridge by a 24 S.W.G. brass strip 2 inches wide screwed into position. The outer roof and the inner roof are screwed together and to the corner posts and rails by ten No. 10 brass countersunk woodscrews  $1\frac{1}{2}$  inches long.

*Thermometer Supports.*—These consist of two  $\frac{3}{4}$  inch by  $\frac{1}{2}$  inch by  $12\frac{1}{2}$  inches strips, 7 inches clear distance apart, let into and screwed to the centre floor board of the screen and screwed also to two  $2\frac{1}{4}$  inches by  $\frac{3}{4}$  inch by  $\frac{1}{2}$  inch blocks screwed to the underside of the inner roof. Four brass clips (Fig. 5B) are screwed to each support (Fig. 15). The right-hand set must be  $\frac{1}{4}$  inch higher than those on the left. The strips are so positioned that the thermometers when placed in the clips lie along the centre line of the screen.

*Painting, etc.*—(See p. 5.)

### 5.—WOODEN STAND FOR STEVENSON SCREENS

A suitably wooden stand is shown in Fig. 9. This consists of four 2 inch by 2 inch straight grained oak legs 5 feet 6 inches long, suitably battened together by means of chamfered boards  $\frac{3}{4}$  inch by 6 inches. Two cross ties  $\frac{1}{2}$  inch by  $\frac{3}{4}$  inch, screwed on 9 inches from the foot of the stand, serve as bracing pieces and also help to give a firm anchorage when buried in the ground. The legs and cross ties should be thoroughly coated with creosote where shown in black on Fig. 9, the remainder being painted white. The dimensions given at the top of the stand are suitable for the standard Stevenson screen ; if any other screen is used the dimensions must be modified accordingly. The stand is firmly fixed in the ground so that the base of the screen when screwed to the stand is about 3 feet 6 inches from the ground level.

### Steel Stands for Standard and Large Type Stevenson Screens

(Fig. 18)

The stand is intended for the purpose of supporting Stevenson screens of the ordinary and large pattern. It consists of 4 uprights of mild steel angle  $1\frac{1}{4}$  inches by  $1\frac{1}{4}$  inches by  $\frac{3}{16}$  inch, overall height 4 feet  $6\frac{1}{2}$  inches, riveted together in pairs by means of two  $1\frac{1}{4}$  inches by  $1\frac{1}{4}$  inches by  $\frac{3}{16}$  inch cross pieces, 1 foot  $3\frac{5}{8}$  inches long. Two diagonal ties of 1 inch by  $\frac{1}{8}$  inch mild steel are riveted across each pair of frames and riveted together at their point of intersection by  $\frac{3}{8}$  inch round head rivets. These two frames are assembled together to form the stand by means of  $1\frac{1}{4}$  inches by  $1\frac{1}{4}$  inches by  $\frac{3}{16}$  inch mild steel angle cross pieces bolted with  $\frac{3}{8}$  inch Whitworth bolts and hexagon nuts top and bottom to form a rigid framework. The length of the cross pieces is either 1 foot  $10\frac{5}{8}$  inches for the standard screen or 3 feet  $8\frac{1}{4}$  inches for the large screen. Two pairs

of suitable length 1 inch by  $\frac{1}{8}$  inch mild steel ties are then bolted with  $\frac{3}{8}$  inch Whitworth bolts and hexagon nuts to the uprights and to each other at their intersection to complete the framework. Four base plates of 5 inches by 5 inches by  $\frac{3}{16}$  inch mild steel are attached by  $\frac{3}{8}$  inch rivets to lugs formed by bending up the faces of the angle iron uprights at right angles. Two lugs consisting of shaped steel plate  $\frac{1}{16}$  inch thick are secured to the outer faces of the upper short side cross pieces by  $\frac{1}{4}$  inch rivets. A hole to take a No. 10 woodscrew is drilled in each at a point  $2\frac{1}{4}$  inches above the top face of the cross piece. Accuracy in assembly is essential and it is important that the distances between the inside faces of the uprights should be adhered to in order that the screen will fit the stand. The metal work of the screen should be galvanized or otherwise protected from the weather.

### Steel Stand for Small Stevenson Screen

(Fig. 19)

This stand is intended for the purpose of supporting the small type of Stevenson Screen for sheathed thermometers only, the lower end of the stand being buried 1 foot deep in the ground when erected.

The four main uprights of the stand consist of 1 inch by 1 inch by  $\frac{1}{8}$  inch mild steel angle. This angle must be of the square inside corner type. The uprights are secured together in pairs by means of two cross pieces welded or riveted on, the upper cross piece being 1 inch by 1 inch by  $\frac{1}{8}$  inch angle welded or riveted to the inside of the upright  $1\frac{1}{2}$  inches from the top and the lower being 2 inches by 2 inches by  $\frac{1}{8}$  inch angle welded to the outside of the upright at the base. The distance between the inside faces of each pair of uprights is very important and must be  $9\frac{7}{8}$  inches  $\pm \frac{1}{16}$  inch. The pairs of uprights are secured together by means of two pairs of cross ties  $1\frac{1}{4}$  inches by  $\frac{1}{8}$  inch, these being bolted to the uprights and to each other by means of ten  $\frac{3}{8}$ -inch Whitworth bolts  $\frac{5}{8}$  inch long with suitable hexagon nuts. The cross ties and the uprights should be accurately drilled, as the distance between the inner faces of the latter when assembled must be 1 foot  $8\frac{7}{8}$  inches  $\pm \frac{1}{16}$  inch. Eight  $\frac{3}{16}$  inch diameter holes are drilled in the top of the uprights and on the centre line of the upper cross pieces for securing the screen to the stand (position of holes shown in Fig. 19). The metal work of the stand should be galvanized or otherwise protected from the weather.

### MATERIALS REQUIRED

The following list gives the total amount of material (wood, screws, etc.) required for the construction of the various types of screens and stands.

Screens

Wood (best yellow pine)

Section.			Standard Screen.	Large Screen.	Small Screen.
ft.	in.	in.	Length. ft. in.	Length. ft. in.	Length. ft. in.
	1½	× 1½	14 0	18 0	—
	1½	× 1	18 0	30 0	5 0
	1½	× 5/16	64 0	101 0	33 0
	1¼	× 5/16	33 0	70 0	—
	2	× 5/16	31 0	31 0	33 0
	2	× 1	6 0	7 4	—
	1	× 1	0 2½	0 2½	—
	¾	× 1½	11 0	16 6	3 0
	1	× 1½	1 9	3 6	0 10
	5	× 1½	4 0	7 6	—
	6	× 1½	2 0	3 9	—
1	4	× 1½	2 0	3 9	—
1	8	× 1	2 0	3 10	—
	1¼	× 1	—	3 0	—
	1½	× 1¾	—	—	5 0
	1½	× 1	—	—	18 0
	6	× ¾	—	—	4 0
	10	× 1½	—	—	2 0
	4	× 1½	—	—	5 6

Mahogany

	Standard Screen.	Large Screen.	Small Screen.
3 in. × 3 in.	0 ft. 1 in.	0 ft. 1 in.	0 ft. 1 in.

Asbestos Cement Sheetting

¼ in.	2 ft. 3 in.	4 ft. 0½ in.	—
	×	×	
	1 ft. 8 in.	1 ft. 8 in.	

Brass Tubing

1½ in. O.D. × 1 in. I.D.	1 ft. 0 in.	1 ft. 6 in.	0 ft. 3 in.
--------------------------	-------------	-------------	-------------

Stamped Brass Chain

24 S.W.G.	1 ft. 8 in.	3 ft. 4 in.	1 ft. 2 in.
-----------	-------------	-------------	-------------

Brass Butt Hinges (Brass Pin)

3 in. × ½ in.	2	3	2
---------------	---	---	---

Brass Strip

½ in. × ½ in.	0 ft. 3 in.	0 ft. 3 in.	—
24 S.W.G.	—	—	2 in. × 2 ft. 0 in.

Brass Panel Pins

¾ in. long	3½ gross	5 gross	2½ gross
------------	----------	---------	----------

Screens—contd.

			<i>Thermometer Clips (Brass)</i>		
			<i>Standard Screen.</i>	<i>Large Screen.</i>	<i>Small Screen.</i>
21 S.W.G. . . . .			—	—	8
			<i>Brass Countersunk Woodscrews</i>		
	<i>Item.</i>				
No. 14 × 3½ in. . . . .			4	4	—
No. 14 × 3 in. . . . .			4	4	—
No. 10 × 1½ in. . . . .			—	—	10
No. 8 × ¾ in. . . . .			10	16	—
No. 8 × ½ in. . . . .			6	12	—
No. 8 × 1¼ in. . . . .			12	12	20
No. 6 × 1¼ in. . . . .			24	36	18
No. 6 × 1½ in. . . . .			4	4	4
No. 6 × ¾ in. . . . .			12	18	12
No. 6 × ½ in. . . . .			6	6	6
No. 4 × ½ in. . . . .			—	—	16
			<i>Brass Round Head Woodscrews</i>		
No. 6 × ½ in. . . . .			—	—	10
			<i>Brass Round Head Bolts</i>		
No. 2 B.A. × 1¾ in. . . . .			4	4	2
No. 2 B.A. × 1¼ in. . . . .			2	2	—
			<i>Lock Nuts (Brass)</i>		
No. 2 B.A. . . . .			12	12	4
			<i>Washers (Brass)</i>		
2 B.A. × ⅜ in. . . . .			6	6	2
			<i>Brass Hasp and Staple</i>		
13 S.W.G. . . . .			1	1	1
			<i>Brass Turn and Catch</i>		
3 in. long . . . . .			1	1	1
			<i>Brass Hook</i>		
11 S.W.G. . . . .			1	2	1
			<i>Brass Eye</i>		
11 S.W.G. . . . .			1	2	1

White Priming Paint, White Enamel and Outdoor Copal Varnish, as required.

Wooden Stands

			<i>Straight grained oak</i>		
			<i>Small Stand.</i>	<i>Large Stand.</i>	
<i>Section.</i>					
2 in. × 2 in.			22 ft. 0 in.	22 ft. 0 in.	
1½ in. × ¾ in.			4 ft. 0 in.	4 ft. 0 in.	
¾ in. × 6 in.			16 ft. 0 in.	25 ft. 0 in.	

**Wooden Stands—contd.***Brass Countersunk Woodscrews*

<i>Section.</i>	<i>Small Stand.</i>	<i>Large Stand.</i>
No. 14 × 2 in.	48	48

Creosote and White Enamel, as required.

**Thermometer Support***Mahogany (straight grained)*

2½ in. × ½ in. × 1 ft. 6 in.    7⁄8 in. × ½ in. × 9 in.    1½ in. × 1½ in. × 1 ft. 6 in.

*Brass*16 S.W.G. × 1½ in. × 3 in.    21 S.W.G. × ½ in. × 1 ft. 0 in.  
(Thermometer Clips).*Phos. Bronze*

24 S.W.G. × ½ in. × 4 in.

*Screws (Brass)*No. 6 × ¾ in. C'sk.—8.    No. 4 × ½ in. C'sk.—16.    No. 6 × 1 in. Rnd.  
Hds.—4.**Steel Stands***Material—Mild Steel (galvanized)*

<i>Section.</i>	<i>Standard Screen.</i>	<i>Large Screen.</i>	<i>Small Screen.</i>
1¼ in. × 1¼ in. × 3⁄16 in. ..	33 ft. 0 in.	40 ft. 0 in.	—
1 in. × 1⁄8 in. .. ..	25 ft. 0 in.	32 ft. 0 in.	—
1 in. × 1 in. × 1⁄8 in. ..	—	—	21 ft. 0 in.
2 in. × 2 in. × 1⁄8 in. ..	—	—	3 ft. 0 in.
1¼ in. × 1⁄8 in. .. ..	—	—	10 ft. 0 in.
16 S.W.G. .. ..	3 in. × 8 in.	3 in. × 8 in.	—

*Rivets (Round Head)*

¼ in. × ½ in. long ..	4	4	—
3⁄8 in. × ½ in. long ..	24	24	8

*Whitworth Hex. Head Bolts and Nuts*

3⁄8 in. × 3⁄4 in. long ..	18	18	—
3⁄8 in. × 5⁄8 in. long ..	—	—	10

*Brass Round Head Woodscrews*

No. 10 × ¾ in. .. ..	2	2	—
No. 8 × ¾ in. .. ..	—	—	8

# STEVENSON SCREEN

STANDARD TYPE

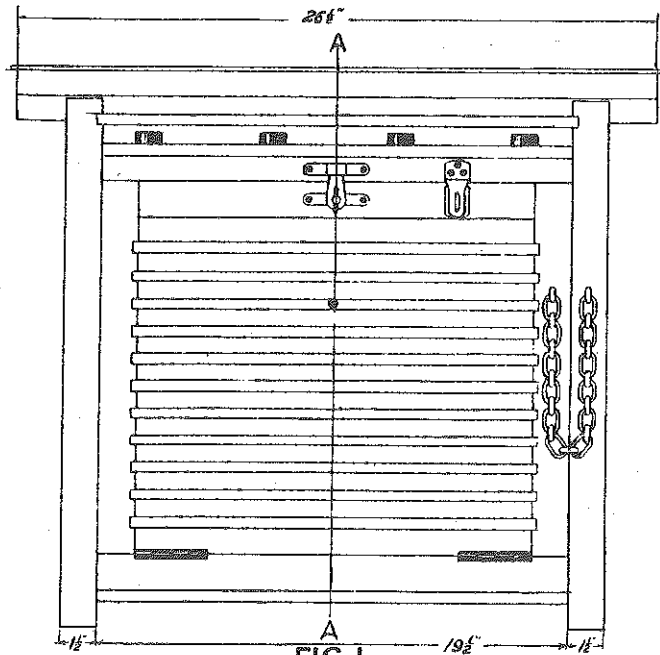


FIG. 1.  
FRONT ELEVATION.

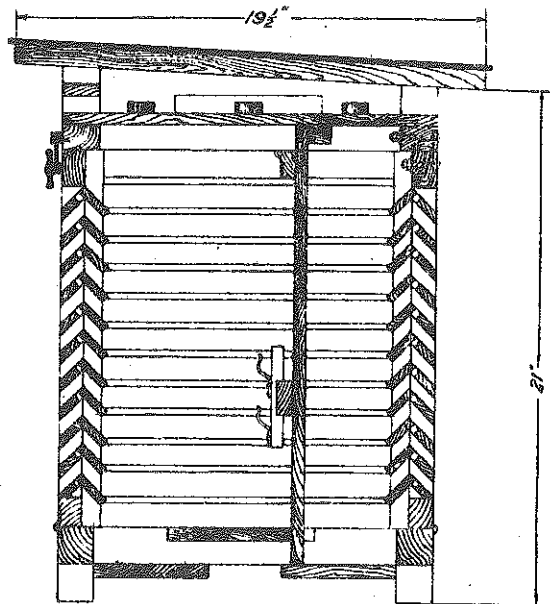
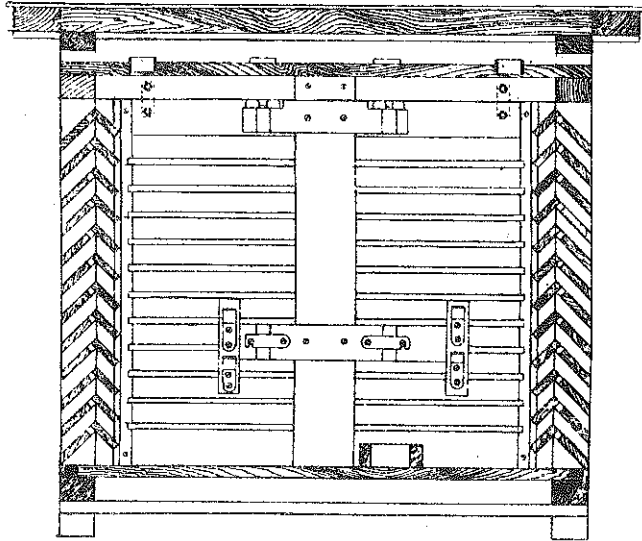


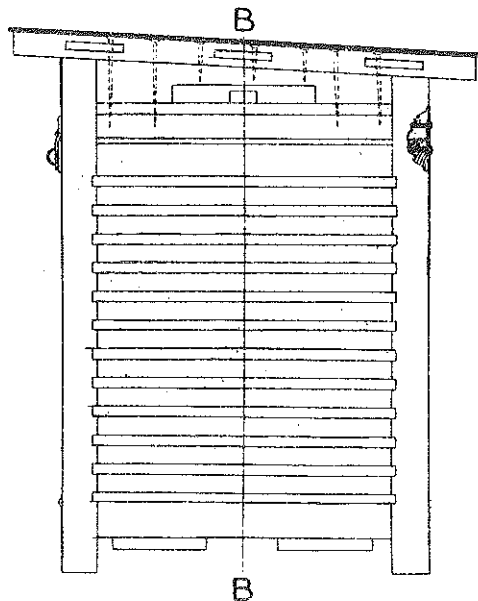
FIG. 2.  
SECTION ON A-A.

# STEVENSON SCREEN

STANDARD TYPE

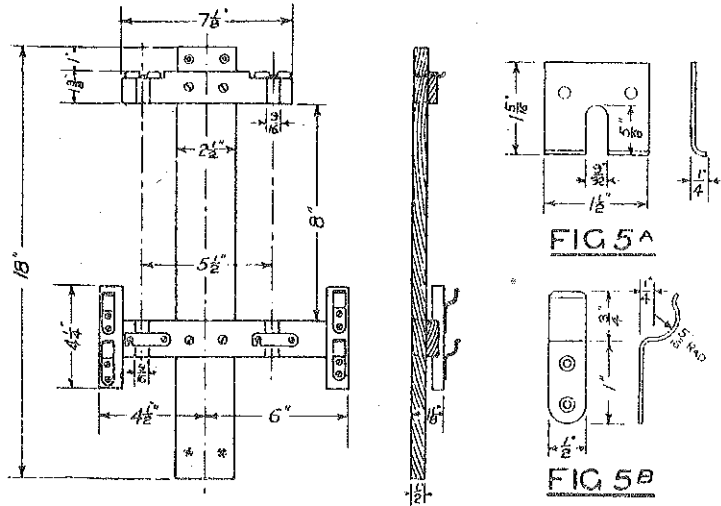


**FIG. 3.**  
**SECTION ON B-B**

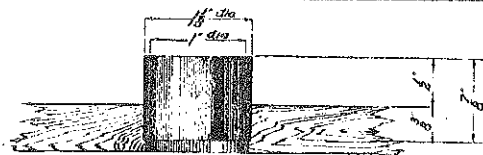


**FIG. 4.**  
**SIDE ELEVATION.**

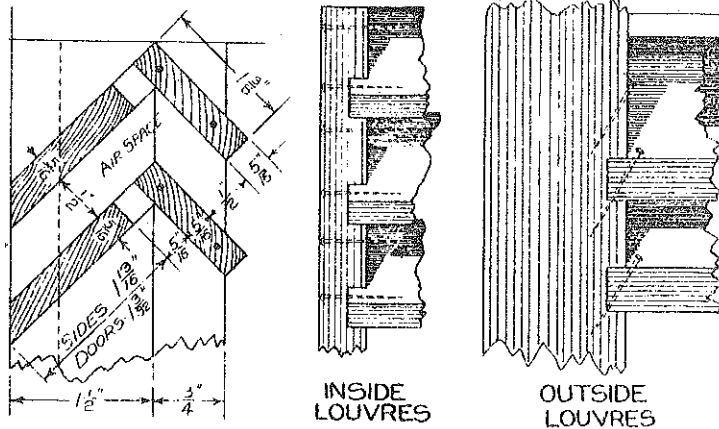
# STEVENSON SCREEN



**FIG 5**  
**SUPPORT FOR SHEATHED THERMOMETERS**  
**WET AND DRY BULB, MAXIMUM AND MINIMUM.**



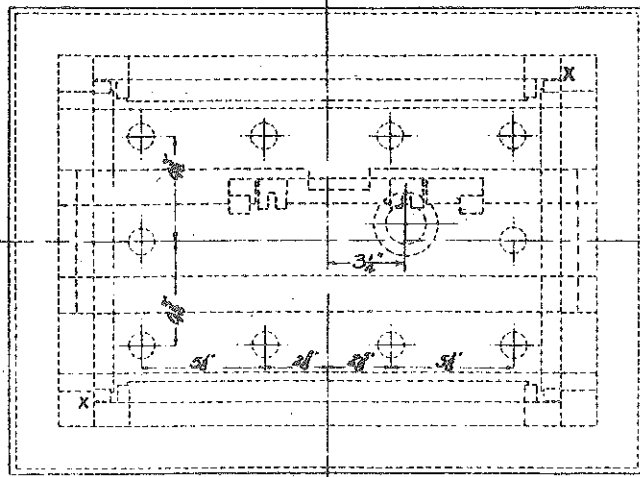
**FIG. 6.**  
**METHOD OF FITTING AIR VENTS.**



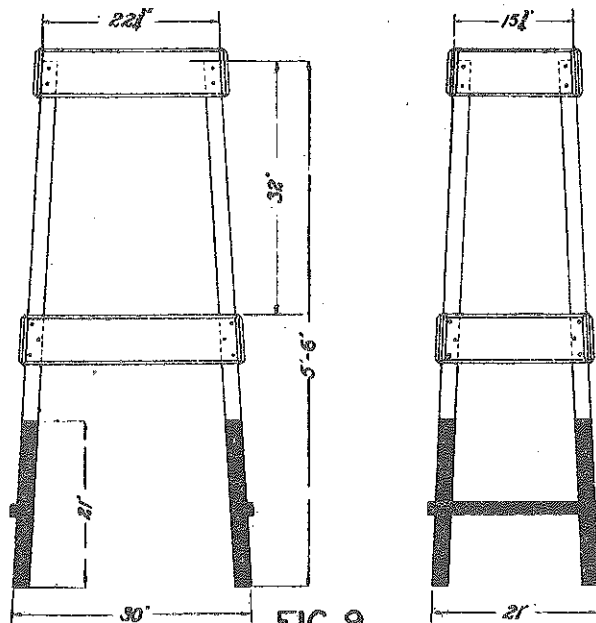
**FIG. 7. METHOD OF FITTING LOUVRES.**

# STEVENSON SCREEN

## STANDARD TYPE



**FIG. 8.**  
**PLAN.**



**FIG. 9.**  
**STAND.**  
**(WOODEN)**

# STEVENSON SCREEN

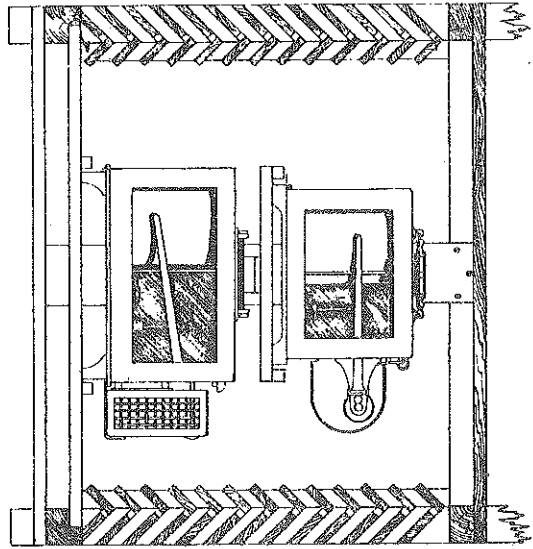


FIG. 10.

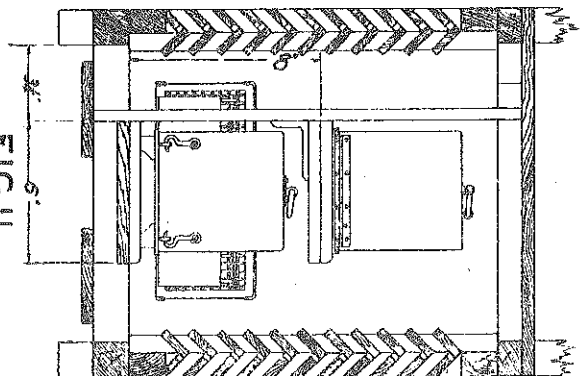


FIG. 11.

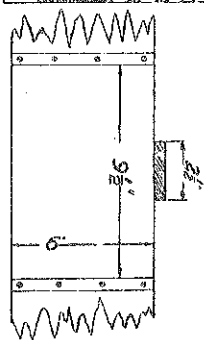


FIG. 12.

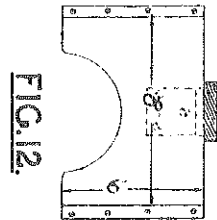


FIG. 13.

MODIFICATION OF STANDARD SCREEN FOR RECORDING INSTRUMENTS.

# STEVENSON SCREEN LARGE TYPE

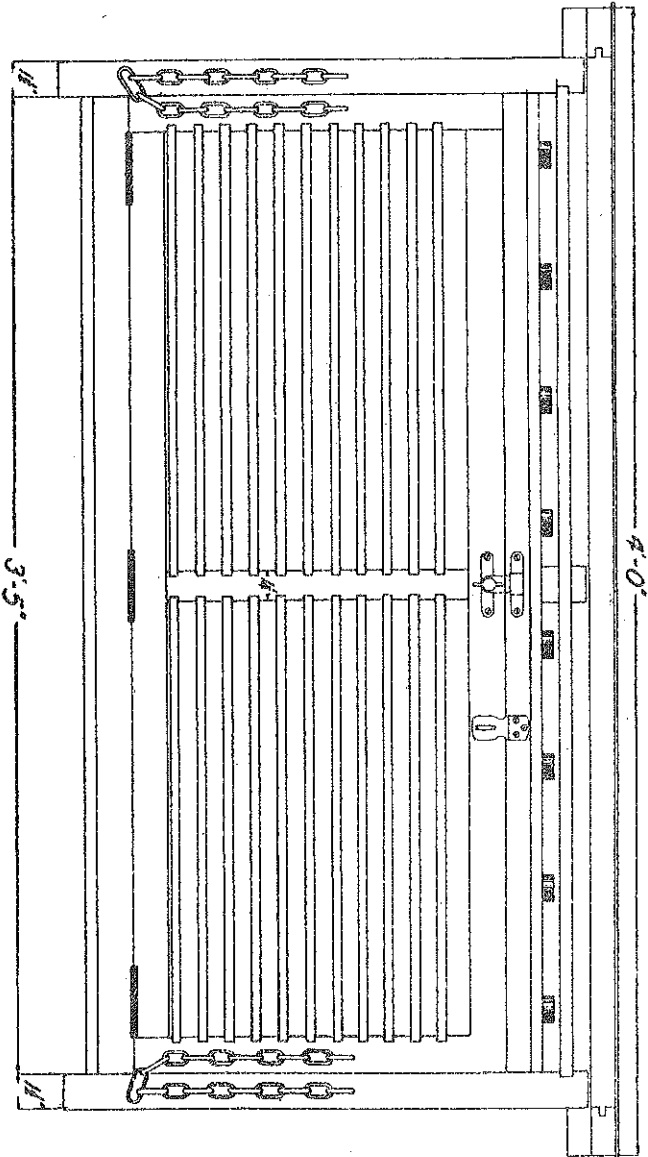
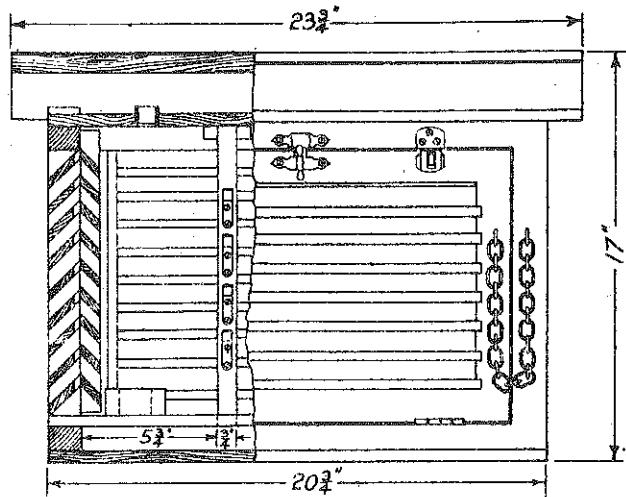


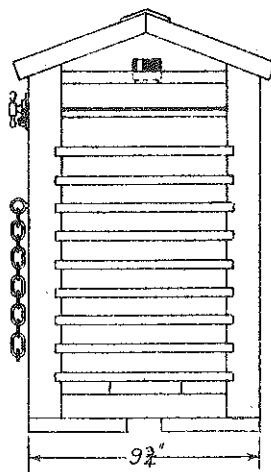
FIG. 14.  
FRONT ELEVATION.

# STEVENSON SCREEN

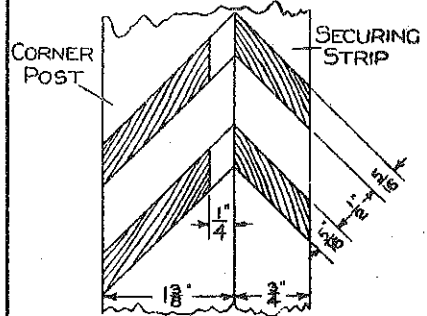
SMALL TYPE FOR SHEATHED THERMOMETERS ONLY



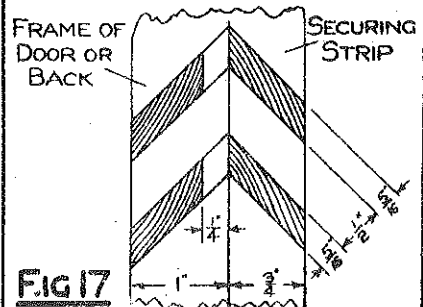
**FIG 15 FRONT ELEVATION**  
PARTLY SECTIONED TO SHOW LOUVRES



**FIG 16**  
**END ELEVATION**

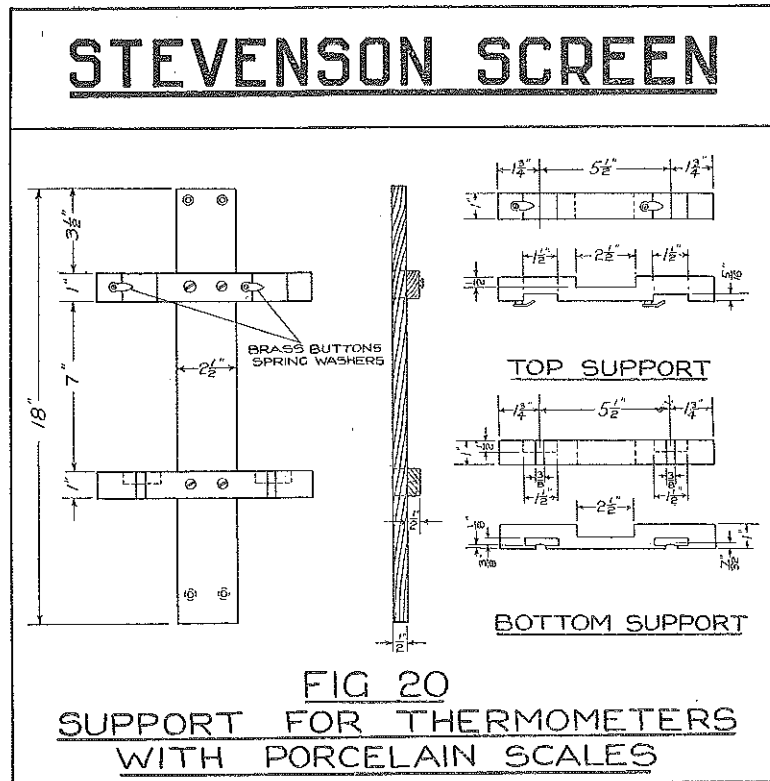


**DETAILS OF SIDE LOUVRES**



**FIG 17**  
**DETAILS OF LOUVRES**  
**OF DOOR AND BACK**





The support shown above is made of well seasoned straight-grained polished mahogany. The upright is similar to that of the support shown in Fig. 5, and is similarly mounted. The lower ends of the porcelain scales of these thermometers rest on shelves cut in the lower cross piece. The upper cross piece is provided with brass buttons for retaining the porcelain scales in slots cut in the front of the cross piece. The arrangements for the water bottle are the same as those described in Section 1 under *Bottom of Screen*.

Maximum and minimum thermometers with wooden mounts are each hung on two brass screws inserted into two vertical wooden uprights, 1 inch wide and  $\frac{1}{2}$  inch thick,  $8\frac{1}{2}$  inches apart and symmetrically placed with respect to the centre of the screen. The lower ends of these uprights rest on the front floorboard and their upper ends against the roof of the screen, and they are screwed with brass screws to the front edge of the middle floorboard and to a block 1 foot long and  $\frac{5}{8}$  inch by  $\frac{1}{2}$  inch section screwed to the underside of the roof.

